

Installation height min. 250mm

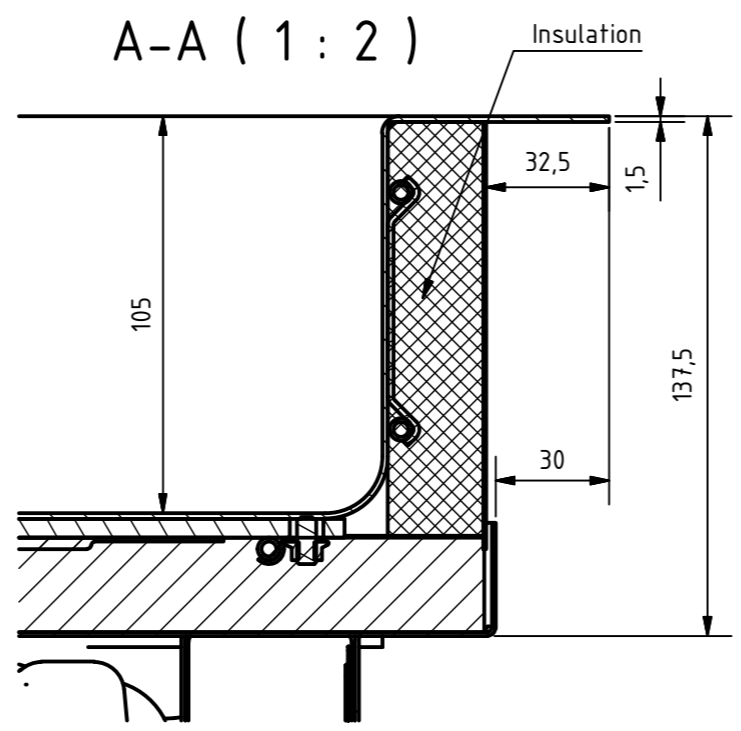

View from below (1 : 4)

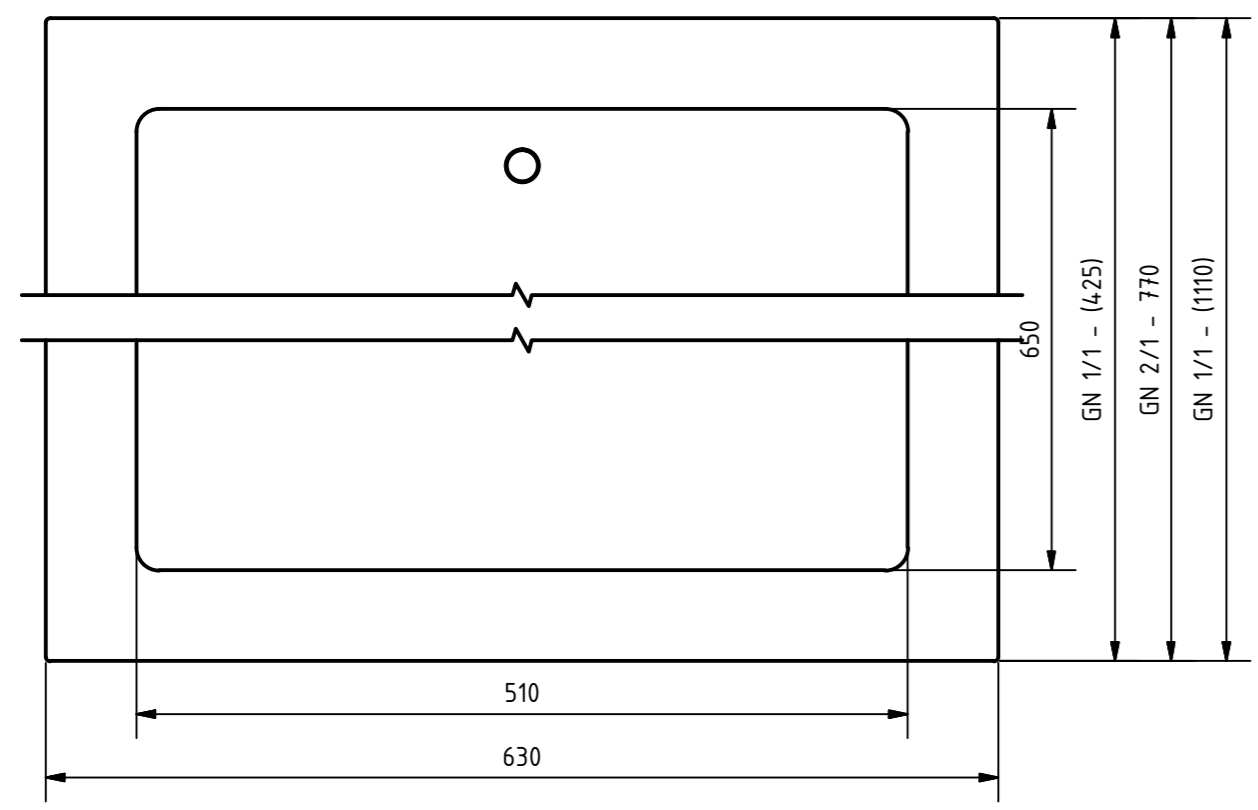
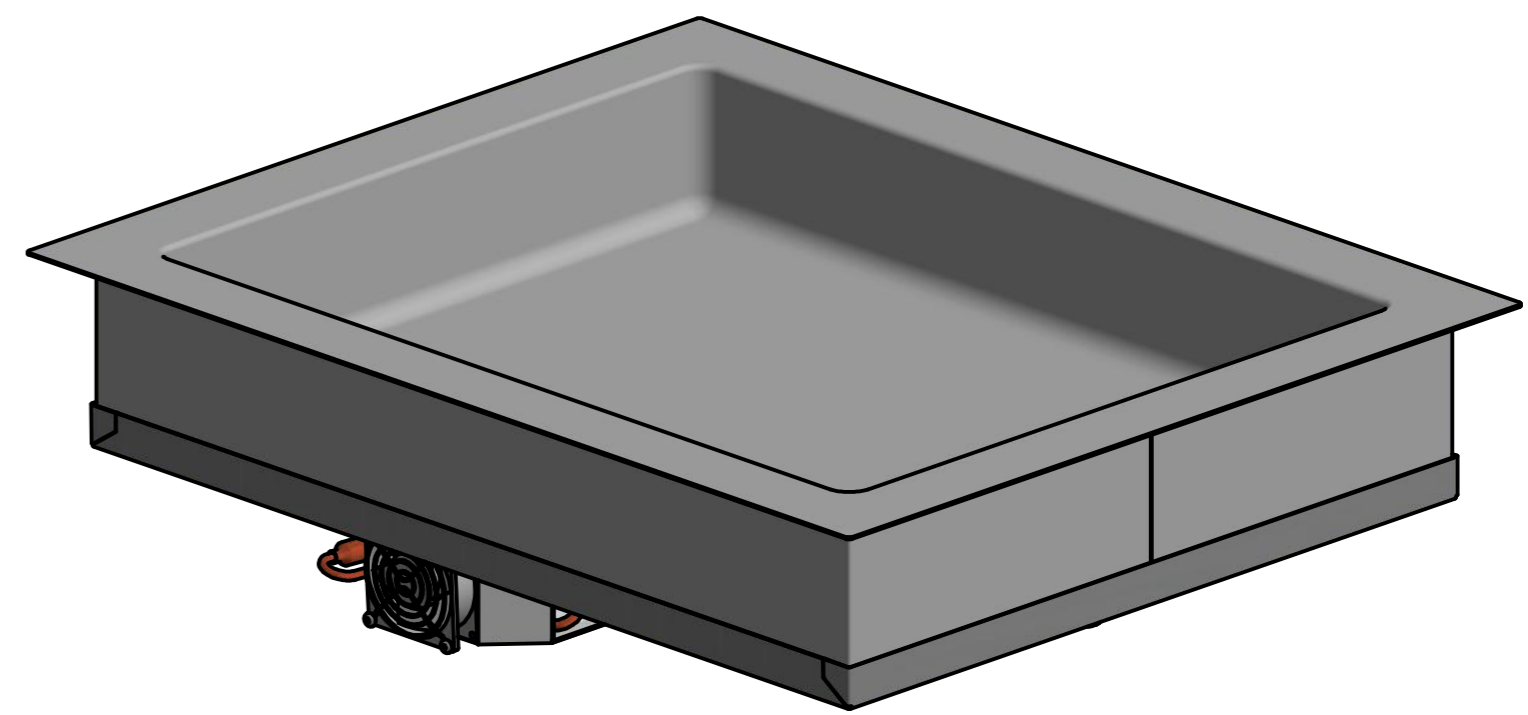
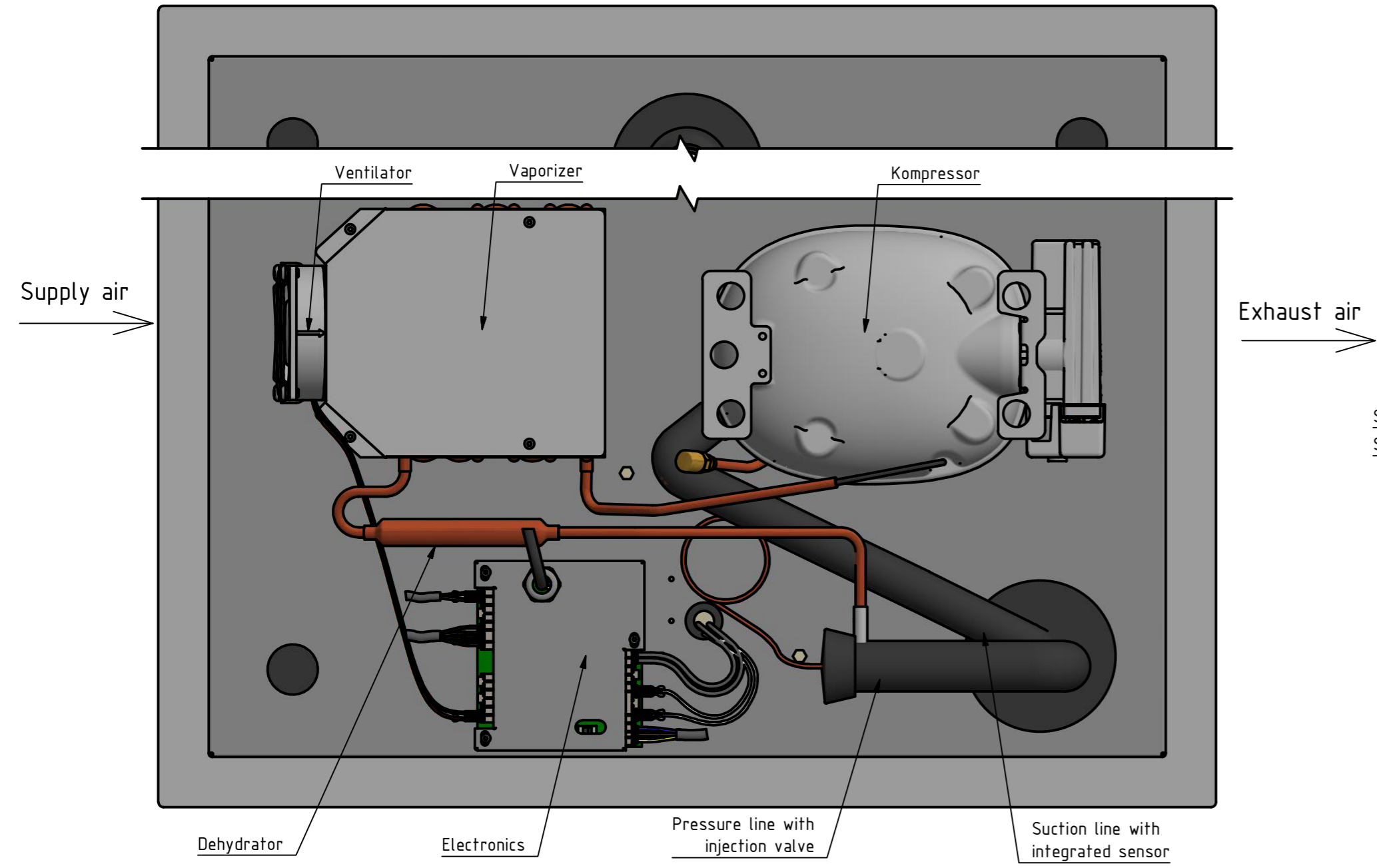
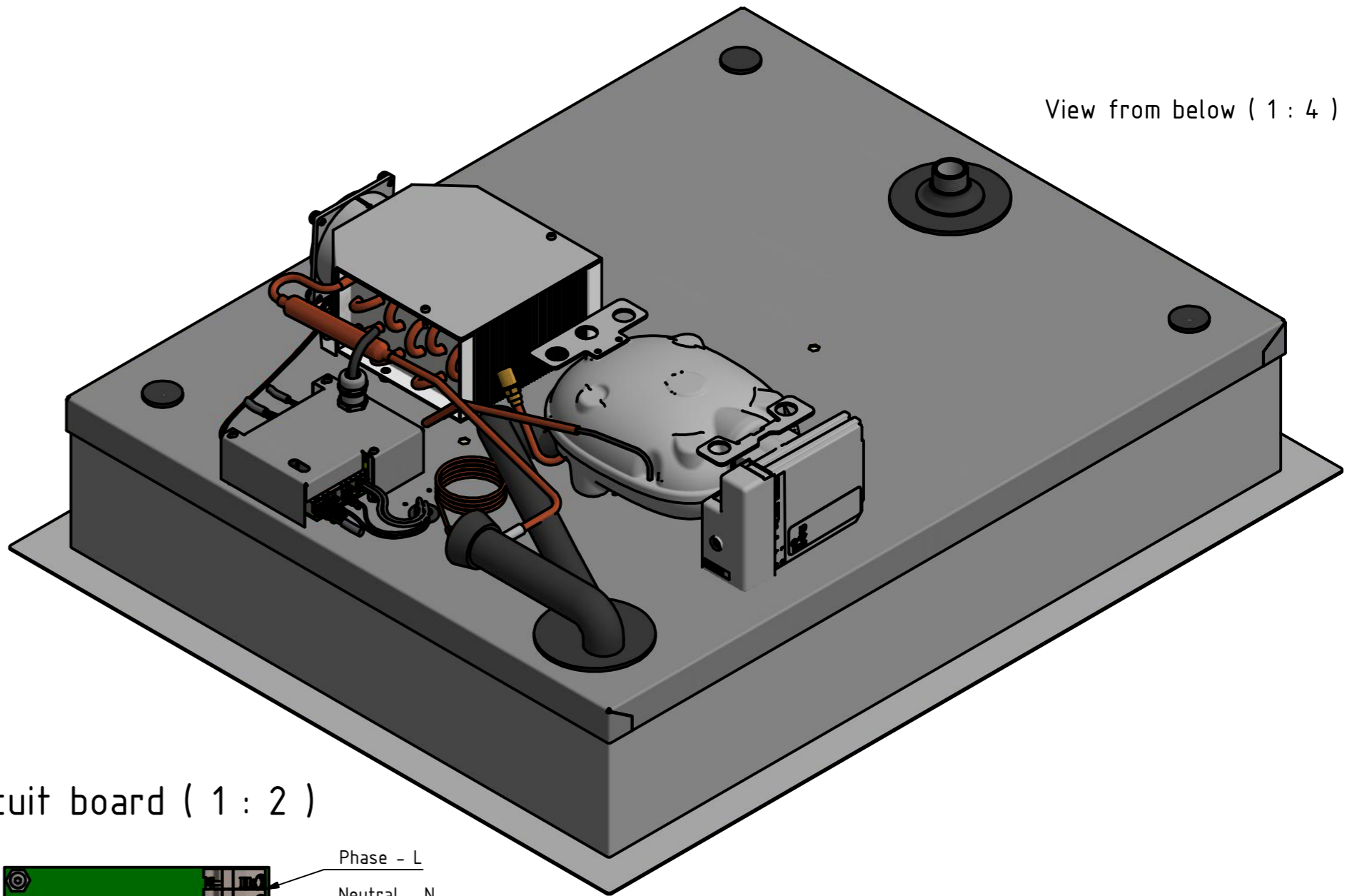

Circuit board (1 : 2)

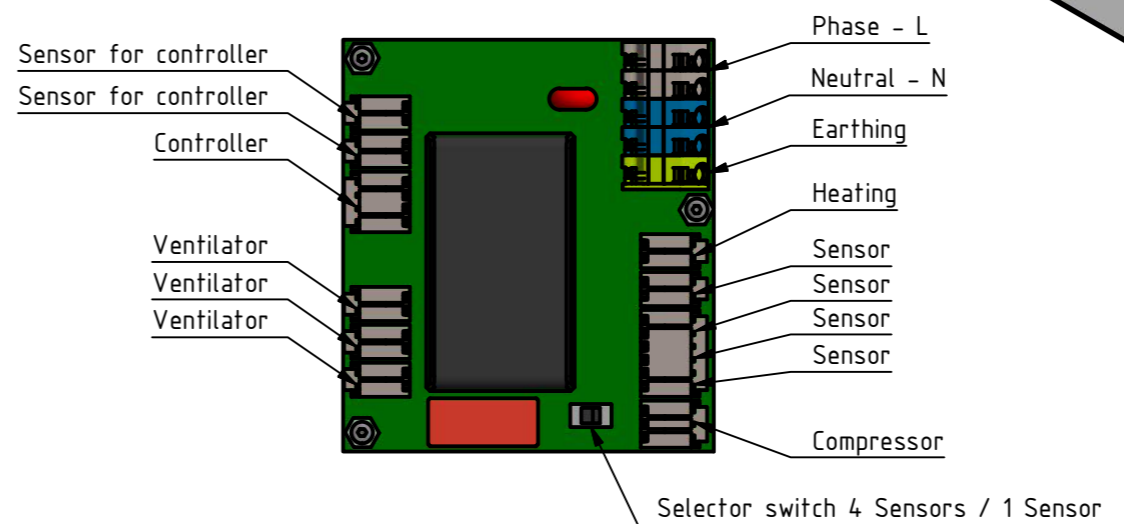

Special Requirement:
The supply air and exhaust air must be ensured in the compact units!

Format overview		
Format	External dimensions	Cut-out dimensions
GN 1/1	425 x 630	375 x 580
GN 2/1	770 x 630	720 x 580
GN 3/1	1110 x 630	1060 x 580

Josef Höller GmbH

Datum	Name	Werkstoff / TS-Nr.:
Gezeichnet: 23.08.2018	MK	
Kontrolliert: 23.08.2018	JH	Oberfläche / Farbe:
Artikelbezeichnung: CCW		
Teilbezeichnung: GN 2/1		

Blattgröße: A2	Maßstab: 1 : 5	Zeichnungsnummer: 14200000	Rev.:
----------------	----------------	----------------------------	-------